



## DATA SHEET

### Features :

- Pb free product—RoHS compliant
- Low power consumption, High efficiency
- Wide viewing angle, High intensity
- I.C. compatible/low current requirement
- Versatile mounting on p.c. board or panel
- General purpose leads

### Package Dimension:

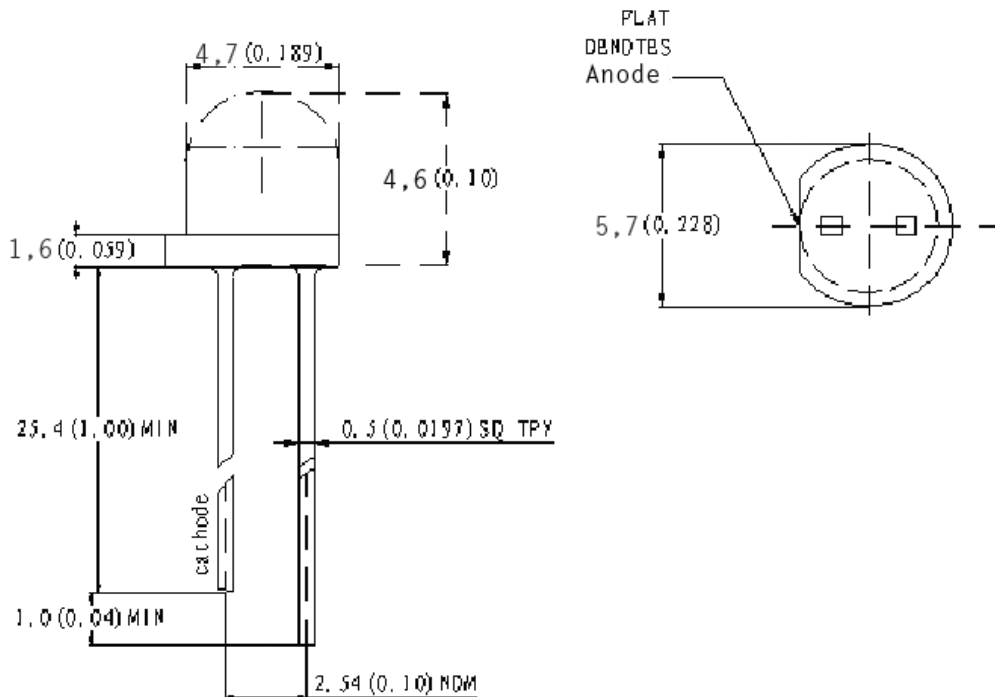

### Notes:

1. All dimensions are in millimeters .
2. Tolerance is  $\pm 0.20$ mm unless otherwise noted.
3. Protruded resin under flange is 1.0mm max
4. Lead spacing is measured where the leads emerge from the package.
5. Caution in ESD:

Static Electricity and surge damages the LED. It is recommend to use a wrist band or anti-electrostatic glove when handling the LED. All devices, equipment and machinery must be properly grounded.



Absolute maximum Ratings at Ta=25°C

Parameter	MAX.	Unit
Peak Forward Current (0,1ms Pulse width)	100	mA
Continuous Forward Current	28	mA
Reverse Voltage	5	V
Derating Linear From 50°C	0.4	mA/°C
Operating Temperature Range	-30°C to + 70°C	
Storage Temperature Range	-30°C to + 70°C	
Lead Soldering Temperature (4mm from body)	260C° for 5 seconds	

Electrical Optical Characteristics at Ta= 25°C

Parameter	Symbol	Min.	Typ.	Max.	Unit	Test Condition
Luminous Intensity	Iv	700	800	---	mcd	IF= 20mA
Viewing Angel		100	120	130	Deg	
Forward Voltage	VF	3,10	3,12	3,15	V	IF=20mA

