



DATA SHEET

Features :

- Pb free product—RoHS compliant
- Low power consumption, High efficiency
- Wide viewing angle, High intensity
- I.C. compatible/low current requirement
- Versatile mounting on p.c. board or panel
- General purpose leads

Package Dimension:

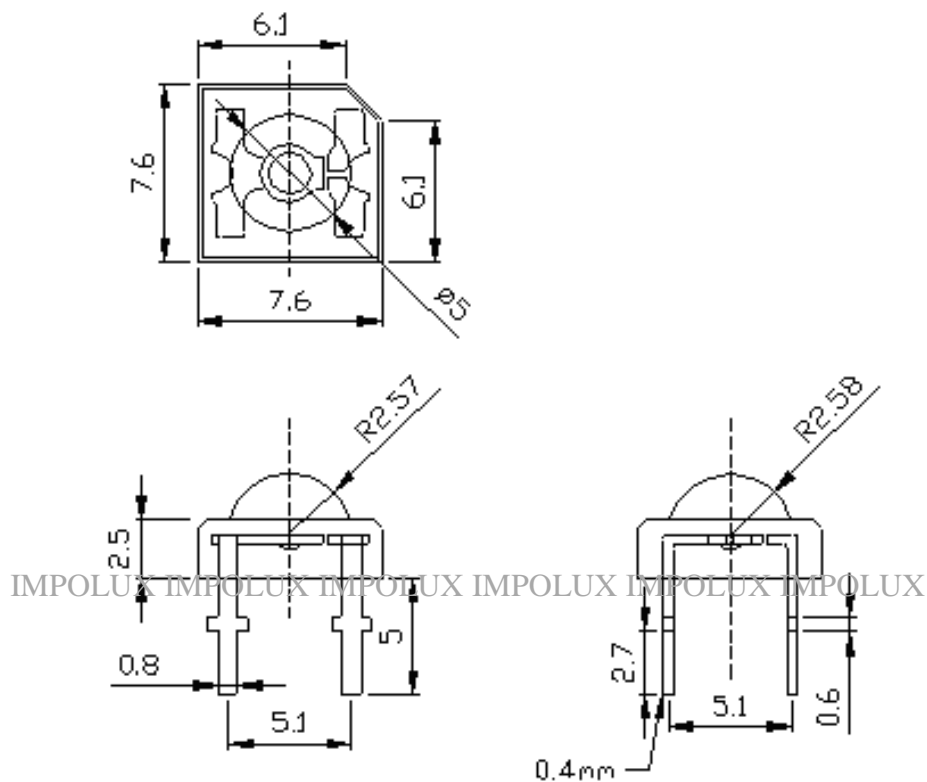

Notes:

1. All dimensions are in millimeters .
2. Tolerance is ± 0.20 mm unless otherwise noted.
3. Protruded resin under flange is 1.0mm max
4. Lead spacing is measured where the leads emerge from the package.
5. Caution in ESD:

Static Electricity and surge damages the LED. It is recommend to use a wrist band or anti-electrostatic glove when handling the LED. All devices, equipment and machinery must be properly grounded.

Absolute Maximum Ratings at Ta=25C°

Parameter	MAX.	Unit
Power Dissipation	100	mW
Peak Forward Current (1/10 Duty Cycle, 0.1ms Pulse Width)	150	mA
Continuous Forward Current	30	mA
Dreading Linear From 50C°	0.4	mA/C°
Reverse Voltage	5	V
Operating Temperature Range	-40 C° to +85 C°	
Storage Temperature Range	-40 C° to +105 C°	
Lead Soldering Temperature [4mm(.157") From Body]	260 C° for 5 Seconds	

Electrical Optical Characteristics at Ta=25C°

Parameter	Symbol	Min.	Typ.	Max.	Unit	Test Condition
Luminous Intensity	Iv	1800	2000	---	mcd	If=20mA (Note 1)
Viewing Angle	2θ1/2	---	100	---	Deg	(Note 2)
Forward Voltage	VF	3,28	3,3	3,32	V	IF=20mA
Reverse Current	IR	---	---	10	μA	VR=5V

Note:

1. Luminous intensity is measured with a light sensor and filter combination that approximates the CIE eye-response curve.
2. $\theta_{1/2}$ is the off-axis angle at which the luminous intensity is half the axial luminous intensity.

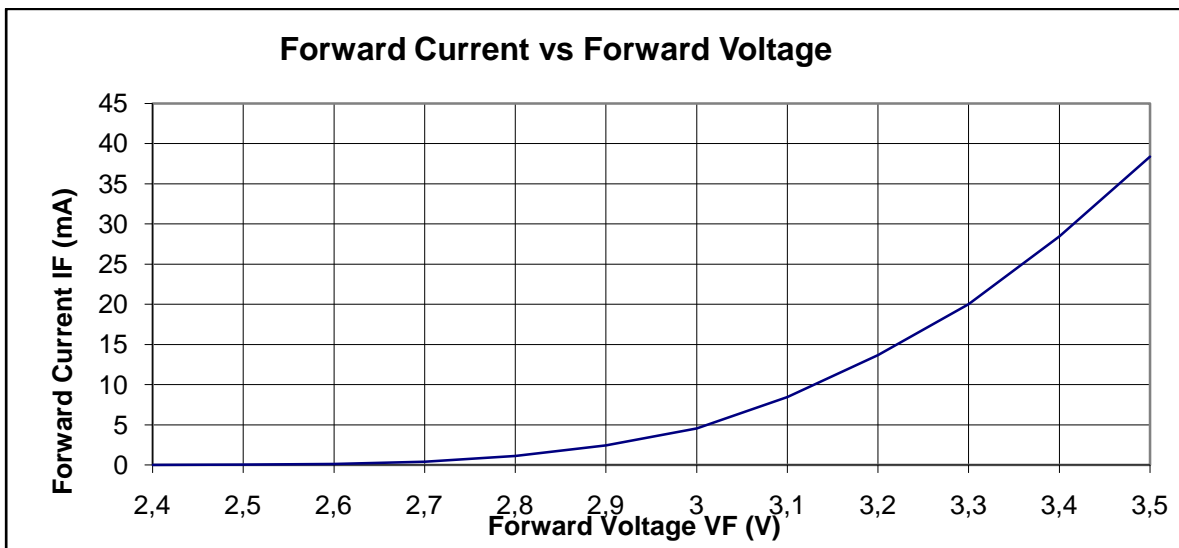
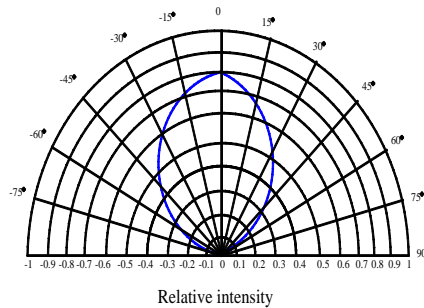

0V

Markierung

Intern
verbunden



Bild von der Unterseite

Intern
verbunden

Widerstand 470Ohm

+
12V